

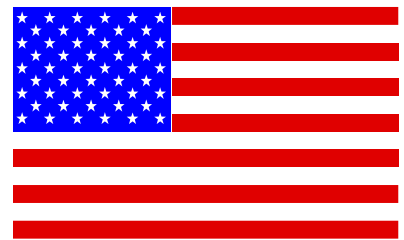

HOUCK INDUSTRIES, Inc.

PRODUCT CATALOG

Functional Hardware For The Cabinet Manufacturer

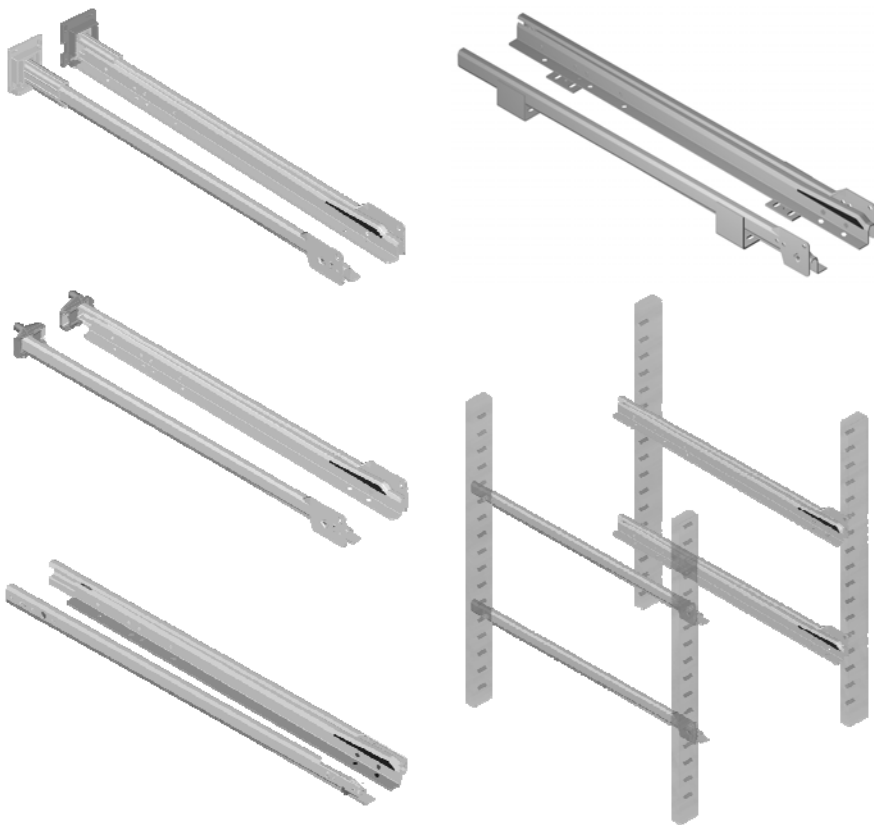

**Houck 100, 200, 500, 950 and
1209 Series Drawer Slides
are Made and Assembled
in the USA by an
American Company**

CORPORATE HEADQUARTERS

814 E Randall Street
P.O. Box 8
Greensburg, IN 47240

Phone: 812.663.5675

Fax: 812.663.5803

URL: www.houckind.com

Customer Service

Vicky Ostendorf ext 222

Email: cs@houckind.com

Sales, Technical Support

Jim Whitacre ext 223

Email: sales@houckind.com

Operations

Rick Fayette ext 221

Email: rick.fayette@houckind.com

Catalog Index:

- 100.01 — CUTTING BOARD STORAGE SLIDES
- 200.01 — 200 SERIES ECONOMICAL DRAWER SLIDE SYSTEM
- 500.01 — 500 SERIES G-O EZ FULLY CONCEALED DRAWER SLIDE
- SSL.01 — 3/4 AND FULL EXTENSION ROLLOUT SHELF DRAWER SLIDES
- 950.01 — 950 SERIES MULTI-FUNCTIONAL DRAWER SLIDE SYSTEM
- B.01 — 200 AND 950 SERIES REAR MOUNTING BRACKETS
- 1209.01 — ADJUSTABLE PANTRY & BASE CABINET SUPPORT SYSTEM
- PIL.01 — PILASTER SPECIFICATIONS

Innovation You Expect From A Name You Trust

100 Series Cutting Board Storage Slides

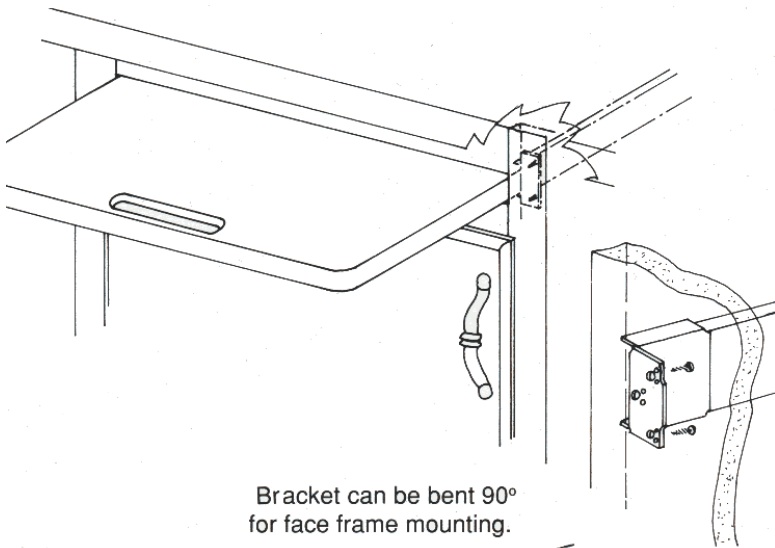

Bracket can be bent 90° for face frame mounting.

SPECIFICATIONS:

Material: Cold Rolled Steel
Colors: Satin, White, Almond
Capacity: **Storage Only**
Fastening: Metal Brackets
Packaging: Pair, 25 Pack, 100 Bulk
Custom Orders: 25 Pair Minimum*

*Custom orders less than 25 pair are accepted, however setup charges will apply to custom orders less than 25 pair. No minimum order quantity for standard stock lengths.

FEATURES:

- Non-Handed channels easily mount to face frame or panel style cabinets
- Slides permit convenient storage of cutting board
- Multi-Function brackets can bent 90 degrees for optional mounting
- Satin slides can be cut to custom lengths by customer

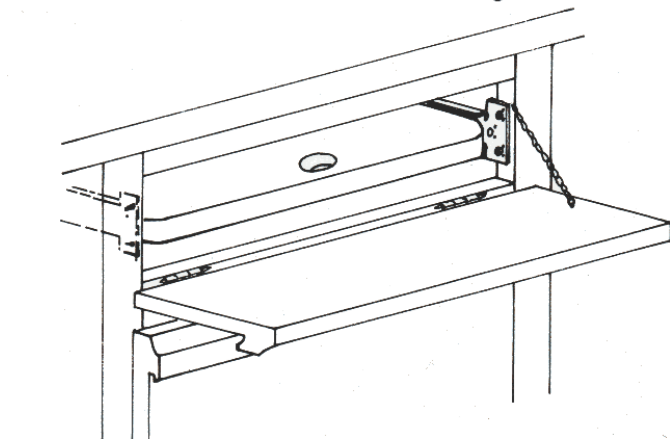

13/16" channel to accommodate 3/4" board

ITEM#	SIZE
100MB21.5	21 1/2" Standard

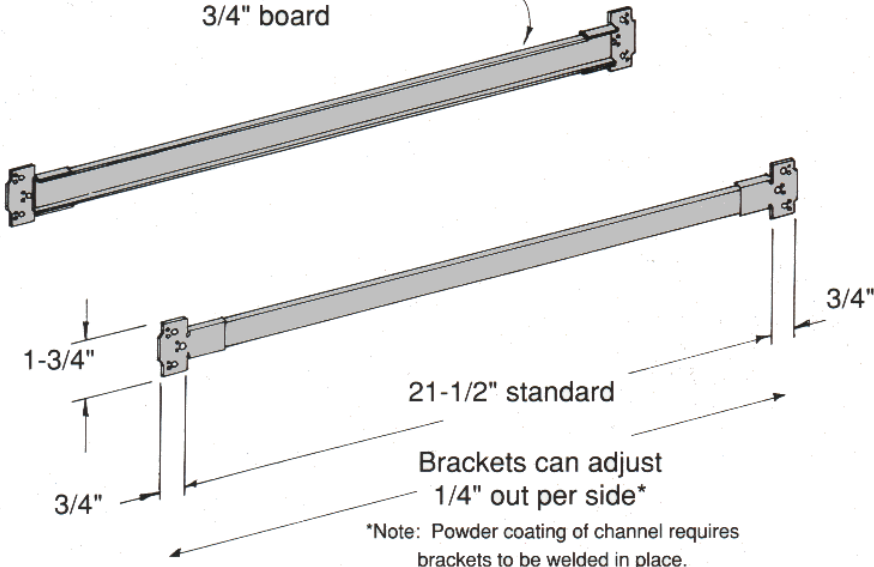
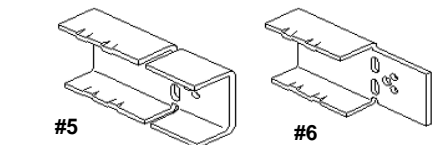
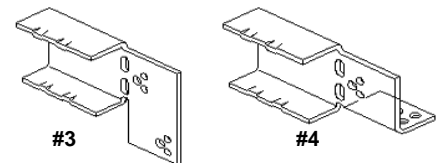
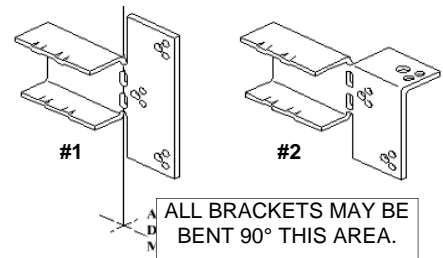

Manufactured and Assembled in the USA

150 Cutting Board Storage Slide

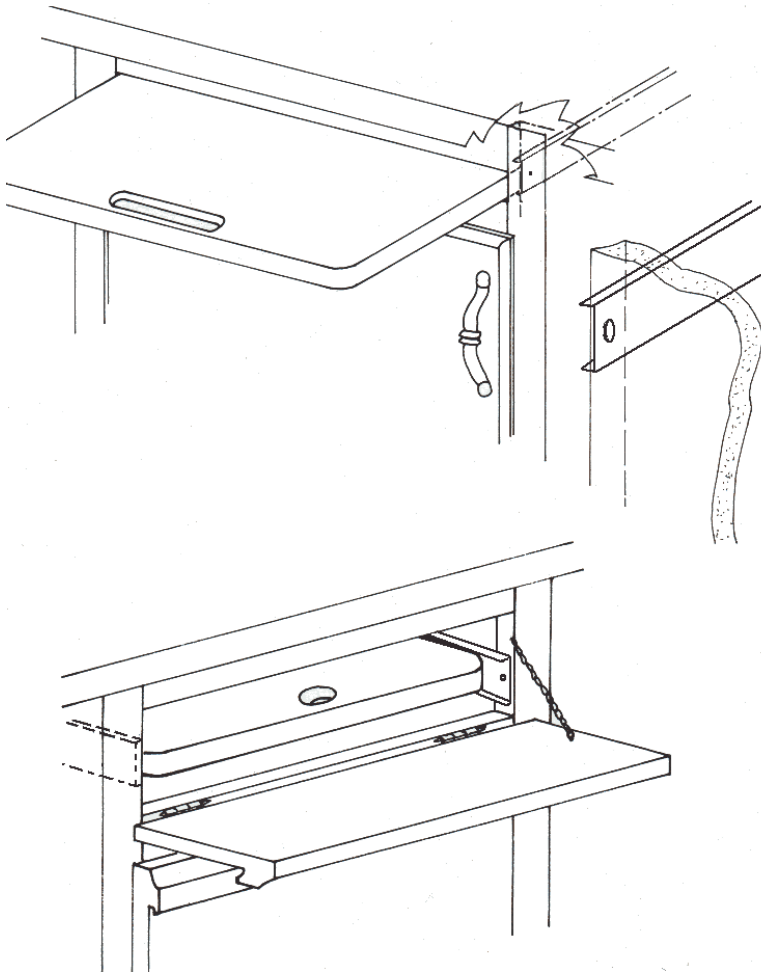

SPECIFICATIONS:

Material: Cold Rolled Steel
Colors: Satin, White, Almond
Capacity: Storage Only
Fastening: V-Notch
Packaging: Pair, 25 Pack, 100 Bulk
Custom Lengths: 25 pair minimum*

*Custom lengths less than 25 pair are accepted, however setup charges will apply to custom lengths less than 25 pair. No minimum order quantity for standard stock lengths.

FEATURES:

- Non-Handed channels easily mount to face frame or panel style cabinets
- Slides permit convenient storage of cutting board
- Integrated rear V-Notch fastening

ITEM#	BOARD SIZE	SIZE
150BB21.5	3/4" THICK	21 1/2" Standard

13/16" or 9/16" channel to accommodate 1/2" or 3/4" cutting board

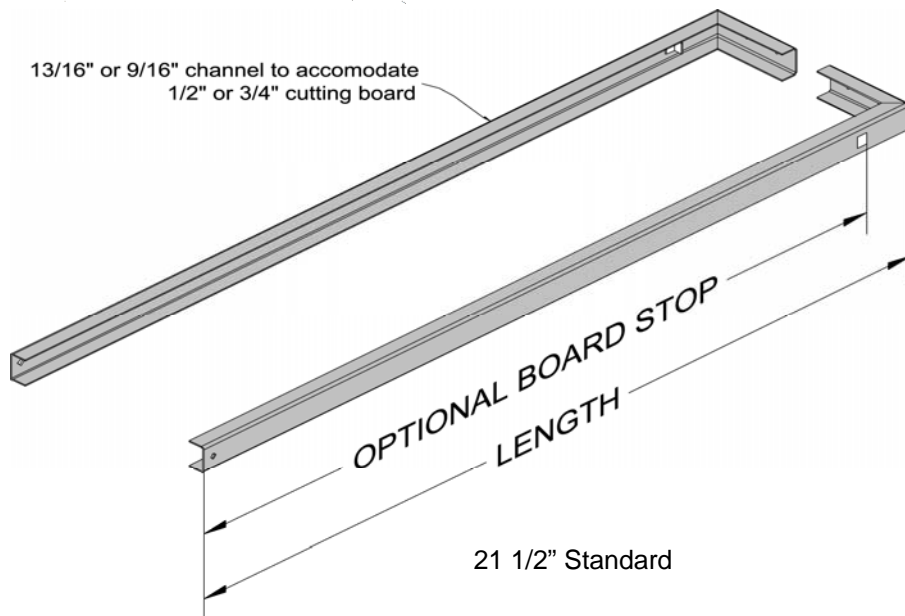

Manufactured and Assembled in the USA

200 Series Slide System

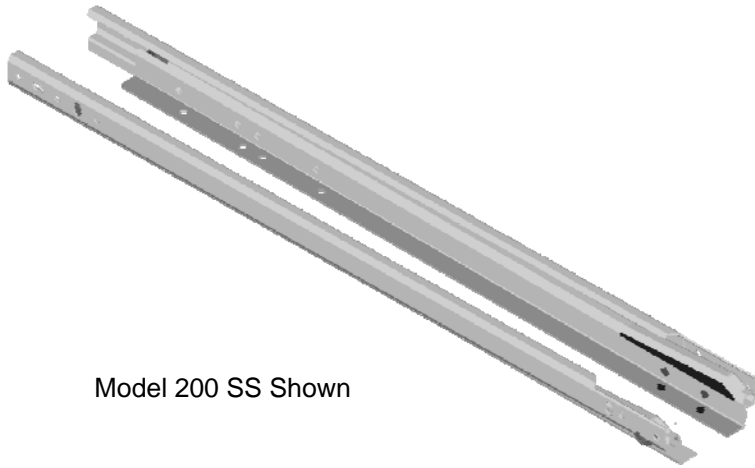

Model 200 SS Shown

SPECIFICATIONS:

- Material:** Cold Rolled Steel
- Colors:** White, Almond
- Capacity:** 75 lbs loading
- Fastening:** Side or Bottom
- Packaging:** Set, 20 Pack, 100 Bulk
- Custom Lengths:** 100 set minimum*

*Custom lengths of less than 100 sets are accepted, however setup charges will apply to custom lengths less than 100 sets. No minimum order quantity for standard stock lengths.

FEATURES:

- Quattro captured for accurate tracking
- Roll formed for smooth, quiet roll
- Patented self-adjusting wheels for mounting tolerances
- Optional brackets
- Standard hole and slot for correctly positioning the slide for installation
- Optional rear configurations are available. See page 950.05 for rear configuration mounting options
- Available in custom lengths up to 32" (load rating will vary on length)
- Custom length 200 SSL available with welded brackets for bottom mount rollout applications.

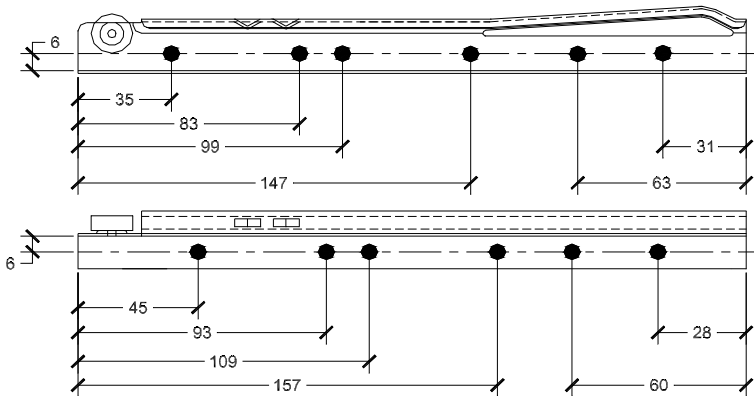

DRAWER TRACK MOUNTING DETAILS

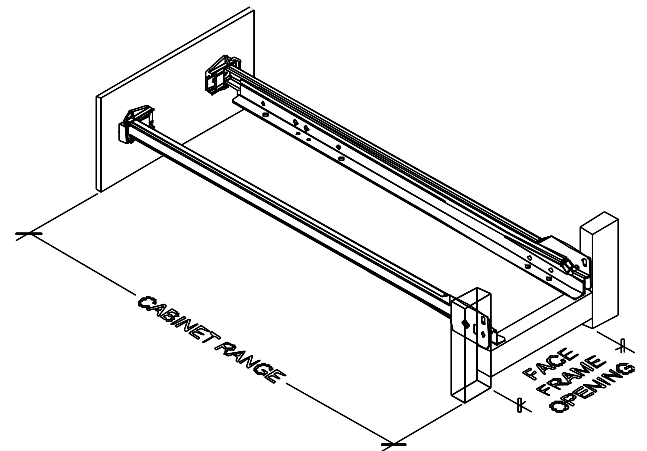

ITEM#	SIZE	CABINET RANGE*
200SS600	24" DT600mm x CT600mm	606mm to 641mm
200SS575	23" DT575mm x CT575mm	581mm to 616mm
200SS550	22" DT550mm x CT550mm	556mm to 591mm
200SS500	20" DT500mm x CT500mm	506mm to 541mm
200SS450	18" DT450mm x CT450mm	456mm to 491mm
200SS400	16" DT400mm x CT400mm	406mm to 441mm
200SS350	14" DT350mm x CT350mm	356mm to 391mm

*Maximum recommended cabinet range with 250 series bracket

BRACKETS SEE CATALOG PAGES: 950.07 THRU 950.09

Manufactured and Assembled in the USA

500 Series Concealed Undermount Slide System

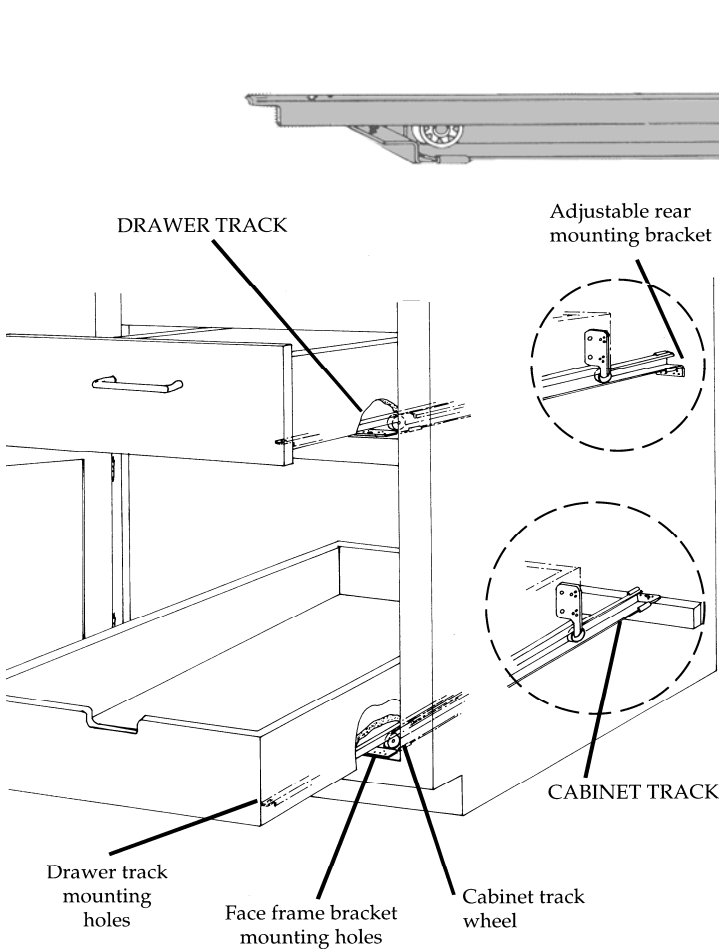

SPECIFICATIONS:

- Material:** Cold Rolled Steel
- Colors:** Satin, White, Almond
- Capacity:** 75 lb cycle, 50 lb edge load*
- Fastening:** Side or Bottom
- Packaging:** Set, 20 Pack or 100 Bulk
- Custom Lengths:** 100 set minimum**

*Per ANSI/BHMA A156.9-2003, 4.11-4.11.4 3.3 Grade 1

**Custom lengths less than 100 sets are accepted, however setup charges will apply to custom orders less than 100 sets. No minimum order quantity for standard stock lengths.

FEATURES:

- **New acetyl wheels provides longer wear and higher load capacity.**
- Concealed system mounts to bottom of drawer for maximum drawer width and clean drawer side appearance
- 4 Point suspension
- Axle exceeds 100 lbs capacity
- Dual dimples provide safety stop / lock open access
- Brackets designed with staple pattern

ITEM#	DRAWER TRACK	CABINET TRACK
524	24"	24-1/2"
522	22"	22-1/2"
521**	20-5/8"	22"
520**	20"	21-1/2"
519**	19"	20 1/4"
518**	18"	19"
517**	17"	18"
516**	16"	16 1/2"
515**	15-1/4"	15-3/4"

REAR MOUNTING BRACKET OP-

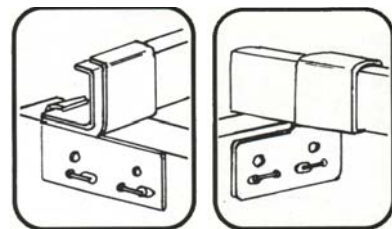

REAR OF RAIL

FRONT OF RAIL

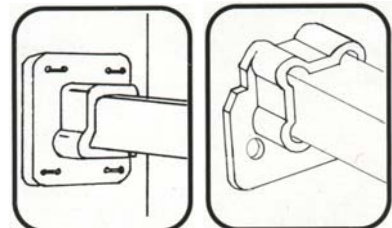

#540

#550

****Special Order, custom length, not in stock**

NEW GO-EZ 522 UNIVERSAL KIT**— 524 kit includes mounting brackets and installation instructions. Parts can be trimmed to replace any length 500 series GO-EZ slides. Perfect for replacements or new installations.

Manufactured and Assembled in the USA

950 SSL Rollout Slide System

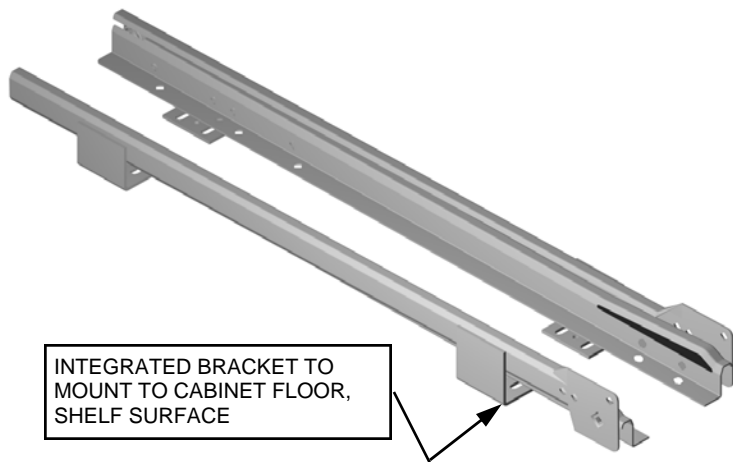

INTEGRATED BRACKET TO MOUNT TO CABINET FLOOR, SHELF SURFACE

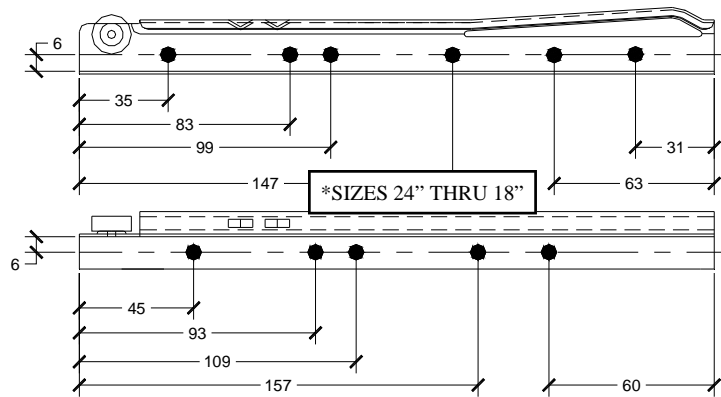
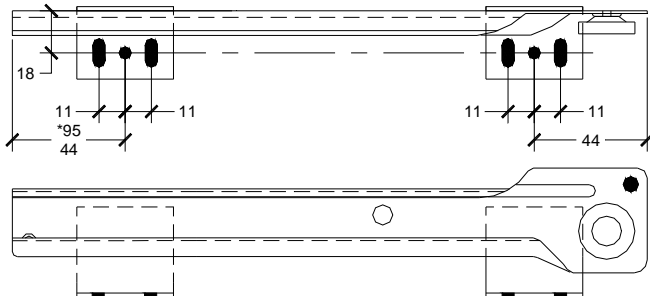

MOUNTING DETAILS

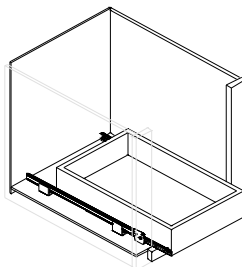

SLIDES IN ROLL-OUT CABINET

SPECIFICATIONS:

Material: Cold Rolled Steel
Colors: White, Almond
Capacity: 100 lbs loading
Fastening: Side or Bottom
Packaging: Set, 20 Pack, 100 Bulk
Custom Lengths: 100 set minimum*

*Custom lengths less than 100 sets are available, however setup charges will apply to custom orders less than 100 sets. No minimum order quantity for standard stock lengths.

FEATURES:

- Quattro captured for accurate tracking
- Roll formed for smooth, quiet roll
- Patented self-adjusting wheels for mounting tolerances
- Integrated welded brackets
- Brackets have slotted holes for correctly positioning the slide for installation and round holes to lock position
- Standard product has all floating wheels to eliminate binding

ITEM#	SIZE
950SSL600	24" - DT600mm x CT600mm
950SSL550	22" - DT550mm x CT550mm
950SSL500	20" - DT500mm x CT500mm
950SSL450	18" - DT450mm x CT450mm
950SSL400	16" - DT400mm x CT400mm
950SSL350	14" - DT350mm x CT350mm
950SSL300	12" - DT300mm x CT300mm
950SSL250	10" - DT250mm x CT250mm

Longer lengths available in 200 series, see page 200.01

Manufactured and Assembled in the USA

Full Extension Ball Bearing SSL Rollout Slide System

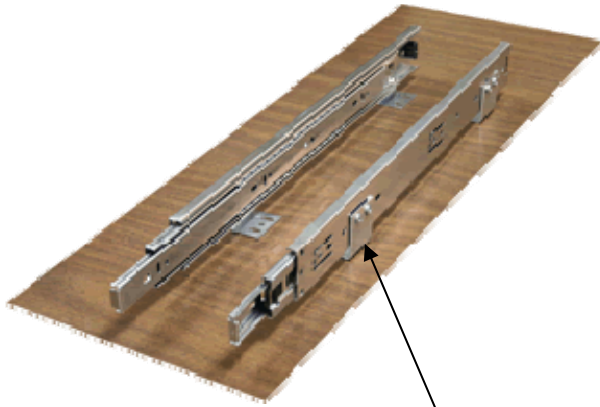

INTEGRATED BRACKET TO MOUNT TO CABINET FLOOR, SHELF SURFACE

SPECIFICATIONS:

Drawer Slides: Full Extension Ball Bearing
Colors: Zinc Plated
Capacity: 100 lbs.
Drawer Fastening: Side
Packaging: Single Kit, 10 Pack

FEATURES:

- Full Extension ball bearing drawer slides.
- Cabinet tracks with attached metal brackets.

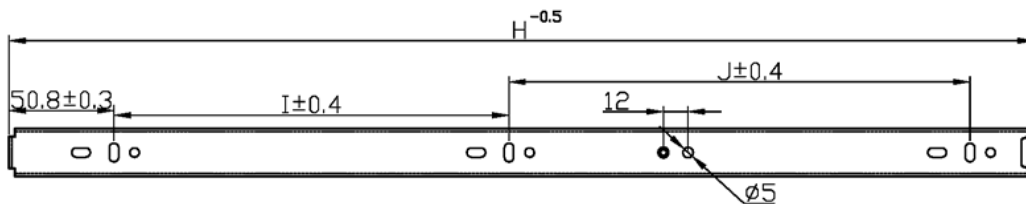

DT MOUNTING DETAILS

ITEM#	SIZE
FXSSL22	22" - DT22" x CT22"
FXSSL20	20" - DT20" x CT20"
FXSSL18	18" - DT18" x CT18"
FXSSL16	16" - DT16" x CT16"

Other lengths available with special order, 2 weeks lead time

Full Extension Drawer Slides are Imported, Final Assembly in the USA

950H Extended Flange Slide System

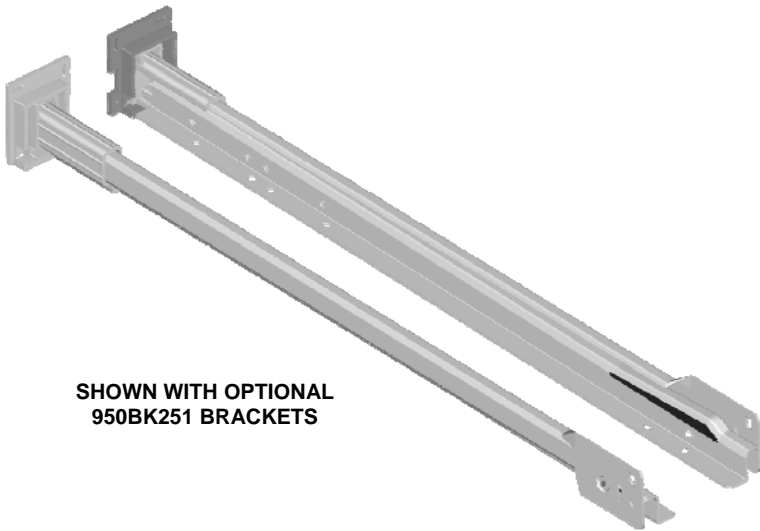

SHOWN WITH OPTIONAL
950BK251 BRACKETS

SPECIFICATIONS:

Material: Cold Rolled Steel
Colors: White, Almond
Capacity: 100 lbs loading
Fastening: Side or Bottom
Packaging: Set, 20 Pack, 100 bulk
Custom Lengths: 100 Set minimum*

*Custom lengths less than 100 sets are available, However setup charges will apply to custom orders less than 100 sets. No minimum order quantity for standard stock lengths.

FEATURES:

- Easy locating and fastening
- Quattro captured for accurate tracking
- Roll formed for smooth, quiet roll
- Patented self-adjusting wheels for standard mill-working and mounting tolerances
- Front flange on cabinet track has locating tab to attain proper 1/16" setback
- Special cabinet track rear bracket mounting options.
- Self-Close / Stay-Close drawer track options
- Optional Roll-Out Tray Feature with 3/4" self-close provides a built in setback clearance for hinges. (Approx. 1/2")
- Available with pre-attached rear 260 or 261 brackets.

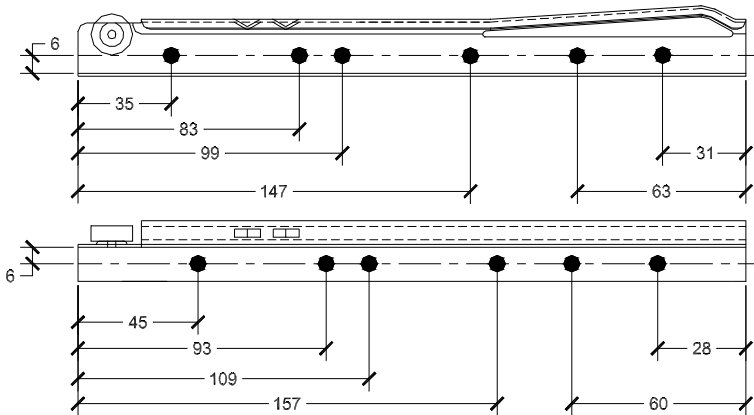

DRAWER TRACK MOUNTING DETAILS

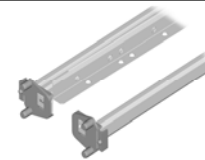

260 brackets for bored
cabinet back

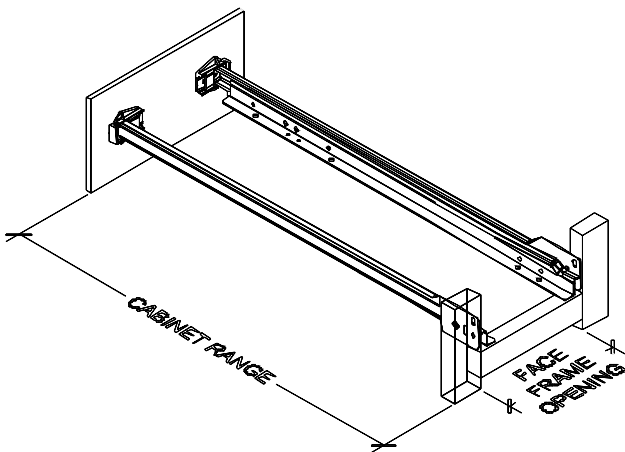

ITEM#	SIZE	CABINET RANGE*
950HS600	24" - DT600mm x CT600mm	606mm to 641mm
950HS550	22" - DT550mm x CT550mm	556mm to 591mm
950HS500	20" - DT500mm x CT500mm	506mm to 541mm
950HS450	18" - DT450mm x CT450mm	456mm to 491mm
950HS400	16" - DT400mm x CT400mm	406mm to 441mm
950HS350	14" - DT350mm x CT350mm	356mm to 391mm

*Maximum recommended cabinet range with 250 series bracket

BRACKETS SEE CATALOG PAGES: 950.06 THRU 950.08

Manufactured and Assembled in the USA

950M Universal Mount Metric Slide System

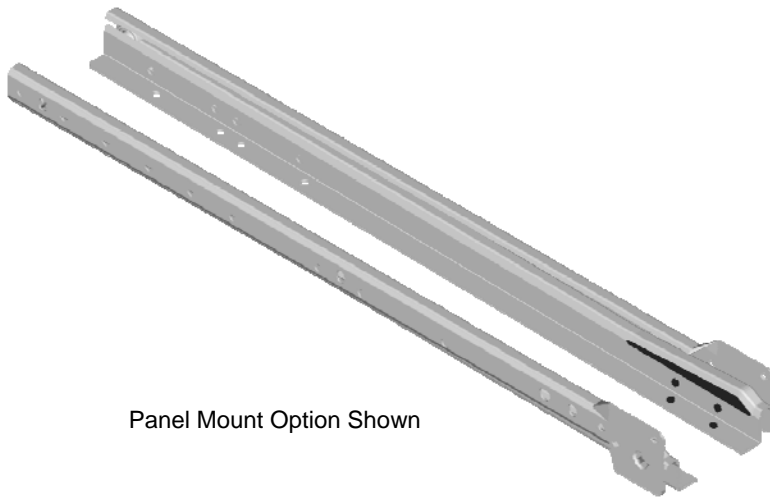

Panel Mount Option Shown

SPECIFICATIONS:

Material: Cold Rolled Steel
Colors: White, Almond
Capacity: 100 lbs loading
Fastening: Side or Bottom
Packaging: Set, 20 Pack, 100 bulk
Custom Lengths: 100 Set minimum*

*Custom lengths less than 100 sets are available, however setup charges will apply to custom orders less than 100 sets. No minimum order quantity for standard stock lengths.

FEATURES:

- Easy locating and fastening
- Universal panel and frame mount
- Quattro captured for accurate tracking
- Roll formed for smooth, quiet roll
- Patented self-adjusting wheels for mounting tolerances
- Optional Self-Closing or Stay-Closing drawer track
- Multiple front and rear configurations are available
- Rear brackets see catalog pages 950.06 through 950.08

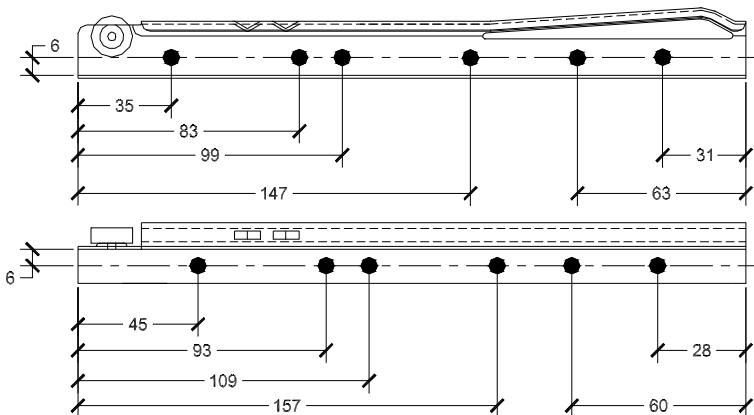

DRAWER TRACK MOUNTING DETAILS

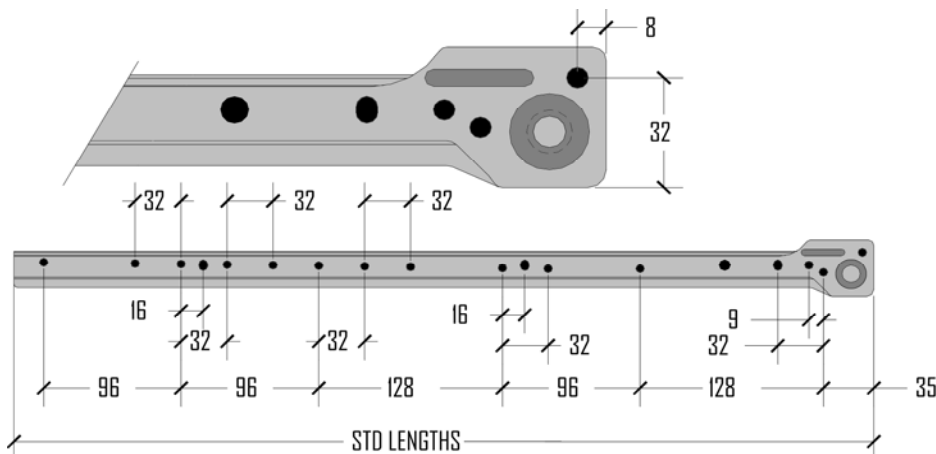

CABINET TRACK MOUNTING DETAILS

ITEM#	LENGTH
950M600	600mm
950M575	575mm
950M550	550mm
950M500	500mm
950M450	450mm
950M400	400mm
950M350	350mm
950M300	300mm
950M250	250mm

Manufactured and Assembled in the USA

950 RV Drawer Retaining Slide System

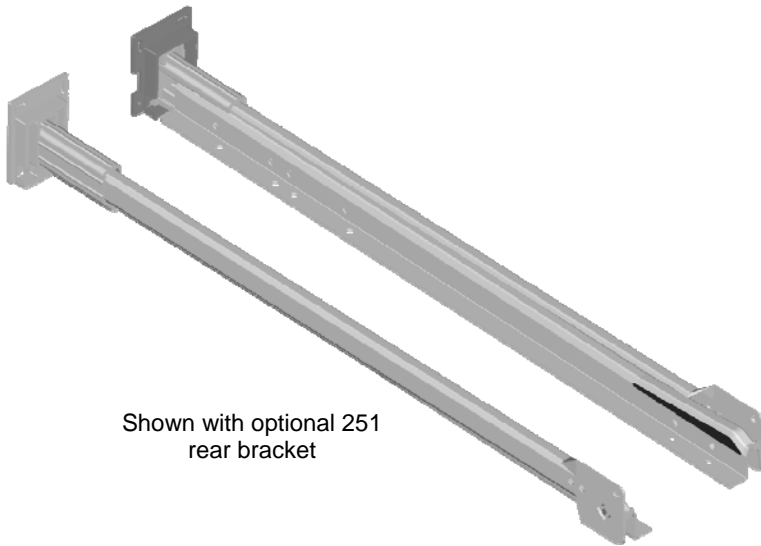

Shown with optional 251 rear bracket

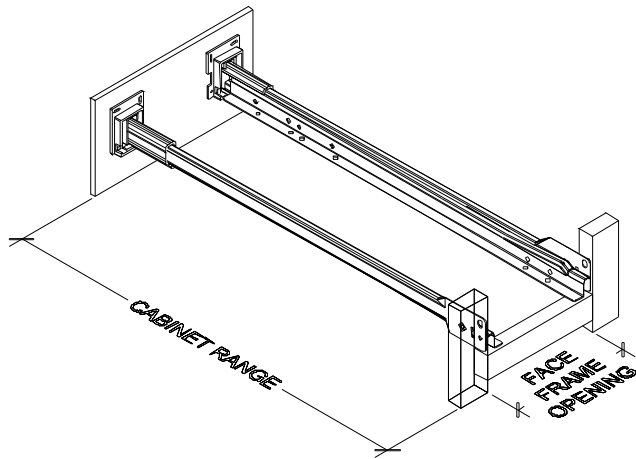

SPECIFICATIONS:

Material: Cold Rolled Steel
Colors: White, Almond
Capacity: 100 lbs loading
Fastening: Side or Bottom
Packaging: Set, 20 Pack, 100 bulk
Custom Lengths: 100 Set Minimum*

*Custom lengths less than 100 sets are available, however setup charges will apply to custom orders less than 100 sets. No minimum order quantity for standard stock lengths.

FEATURES:

- Tab Retainer provides a positive drawer lock to prevent unwanted opening of the drawer
- RV-Spike eases fastening of cabinet track
- Quattro captured for accurate tracking and extra retaining to insure wheels will stay in tracks
- Roll formed for smooth, quiet roll
- Patented self-adjusting wheels for mounting tolerances
- Self-Closing drawer track
- Special cabinet track rear mounting options

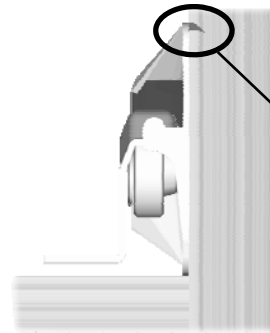

RV-SPIKE ALLOWS CABINET TRACK TO BE HELD IN POSITION WHILE INSTALLING

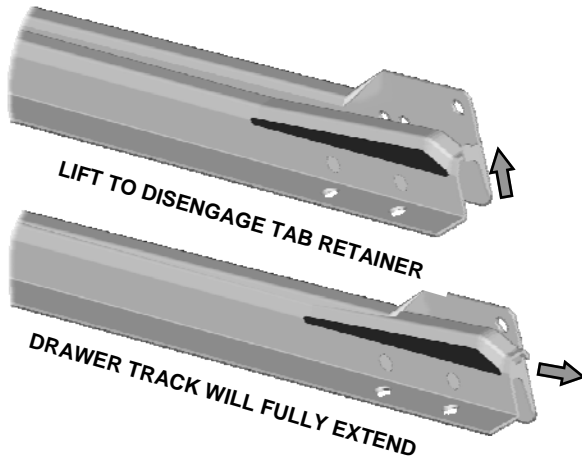

LIFT TO DISENGAGE TAB RETAINER

DRAWER TRACK WILL FULLY EXTEND

ITEM#	SIZE	CABINET RANGE*
950RVS600	24" - DT600mm x CT600mm	606mm to 641mm
950RVS575	23" - DT575mm x CT757mm	581mm to 616mm
950RVS550	22" - DT550mm x CT550mm	556mm to 591mm
950RVS500	20" - DT500mm x CT500mm	506mm to 541mm
950RVS450	18" - DT450mm x CT450mm	456mm to 491mm
950RVS400	16" - DT400mm x CT400mm	406mm to 441mm
950RVS350	14" - DT350mm x CT350mm	356mm to 391mm
BRACKETS	SEE CATALOG PAGE: 950.06 THRU 950.08	

*Maximum recommended cabinet range with 250 series bracket

Manufactured and Assembled in the USA

200 and 950 Series Custom Fastening Options



200 and 950 Series Rear Fastening Configuration Options

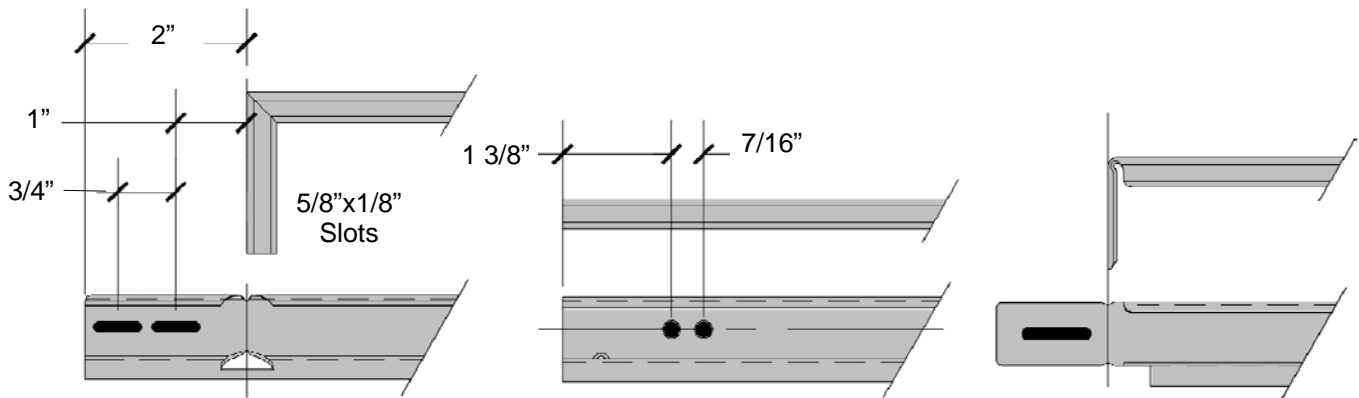

“V-NOTCH” REAR
Integrated pre-bent rear that fastens directly to cabinet back. No bracket required

“S” REAR
Standard rear to be used with brackets 950BK240, 950BK241, 950BK250 & 950BK251

“P-BEND” REAR
Pre-Bent to be used with integrated plastic bracket 260.3125, 260.4375, 260.6875 & 950BK261

950 Series Front Fastening Configuration Options*

Custom Front Configurations Available, Call for Details

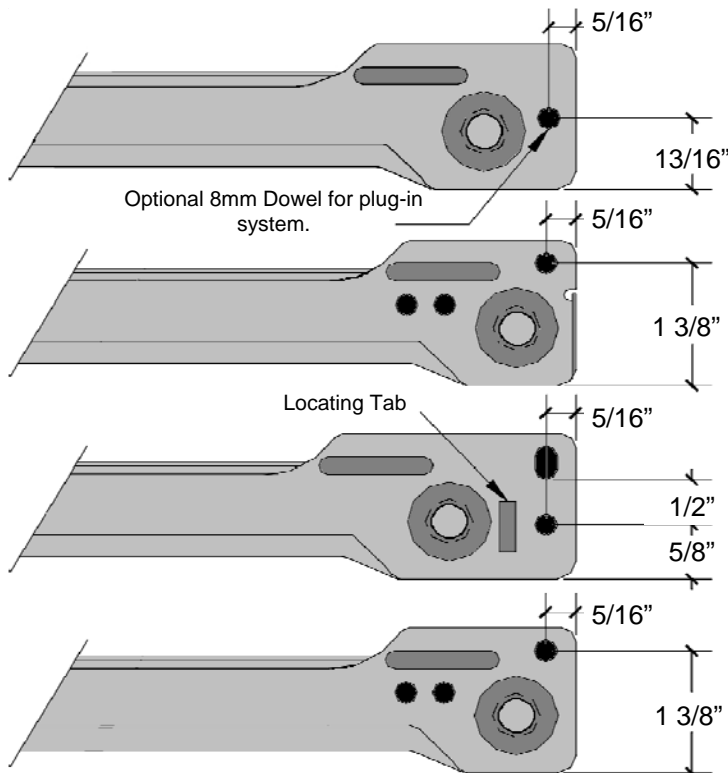

“C” FRONT
Centered hole flange configuration for frame mounting or optional plug-in. 3/8" setback available with 9/16" self-close.

“RV” FRONT
Recreation vehicle and child lock retaining tab system. Provides positive lock, must lift drawer over tab to pull drawer out.

“H” FRONT
Extended flange for approximate 1/2" roll out tray setback to clear hinges.

“S” FRONT
Standard hole configuration

Manufactured and Assembled in the USA

200 and 950 Series Standard Rear Mounting Brackets



251 2-Way Adjustable

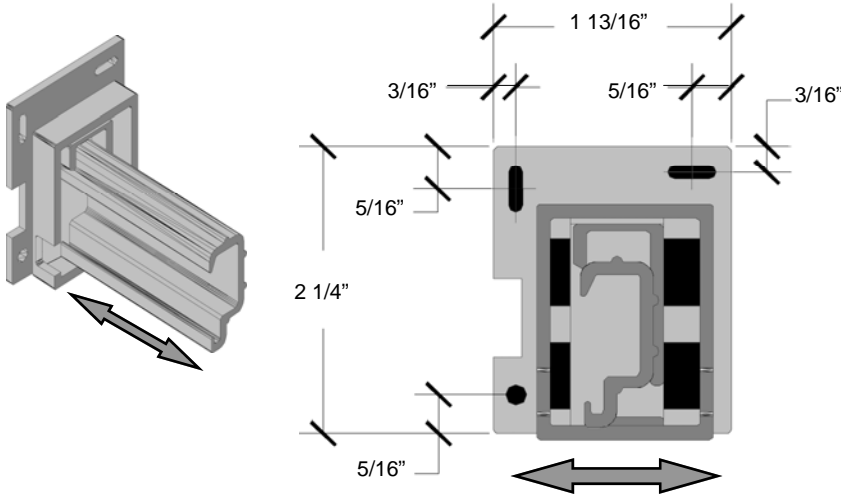

Bracket Description:

#950BK251 bracket has built in longitudinal and latitudinal adjustment.

Screw Fastening:

3 pan head #6 screws located in provided holes.

Cabinet Track Installation:

Cabinet track must be inserted in the bracket a minimum of 1 1/2\"/>

ITEM#	SIZE	SOLD IN PAIRS
950BK251R	ADJUSTABLE REAR BRACKET—RIGHT HAND	
950BK251L	ADJUSTABLE REAR BRACKET—LEFT HAND	

250 One Way Adjustable

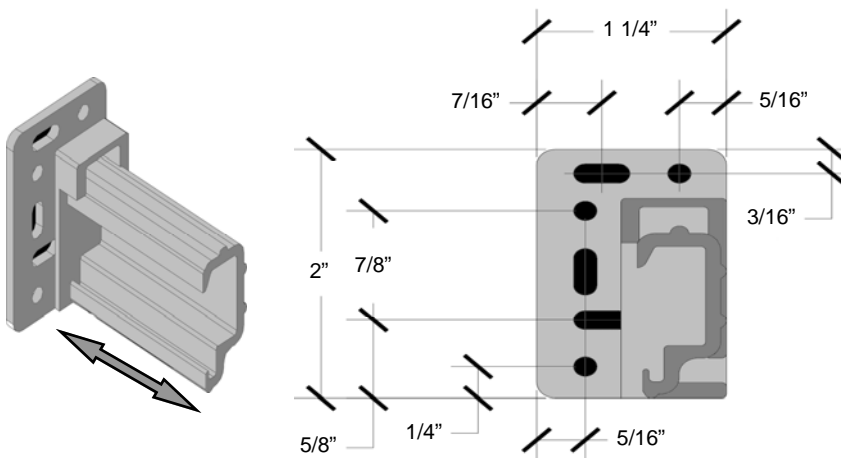

Bracket Description:

#950BK250 bracket has built in longitudinal adjustment.

Screw Fastening:

3 pan head #6 screws located in provided holes.

Cabinet Track Installation:

Cabinet track must be inserted in the bracket a minimum of 1 1/4\"/>

ITEM#	SIZE	SOLD IN PAIRS
950BK250R	ADJUSTABLE REAR BRACKET—RIGHT HAND	
950BK250L	ADJUSTABLE REAR BRACKET—LEFT HAND	

Made in the USA

200 and 950 Series Standard Rear Mounting Brackets



241 Hanging Strut Bracket

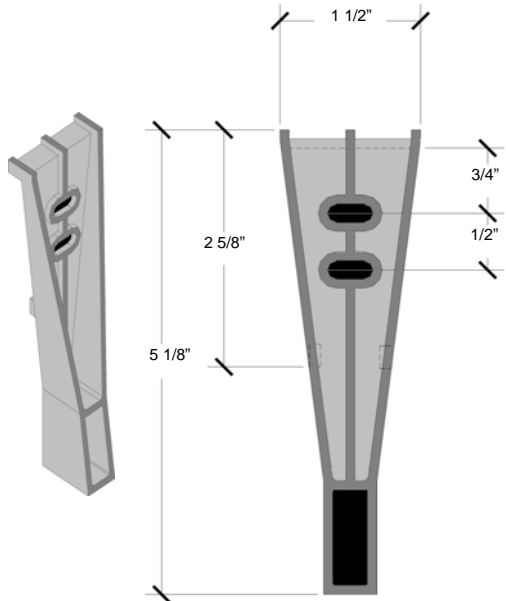

Bracket Description:

#950BK241 bracket can be hung from nailer strip or fastened in cabinet back dato groove.

Fastening:

2 washer head #8 screws x 1" located in provided holes.

ITEM#	SIZE	SOLD IN PAIRS
950BK241	ADJUSTABLE REAR BRACKET—NON-HANDED	

240 Seated Plate

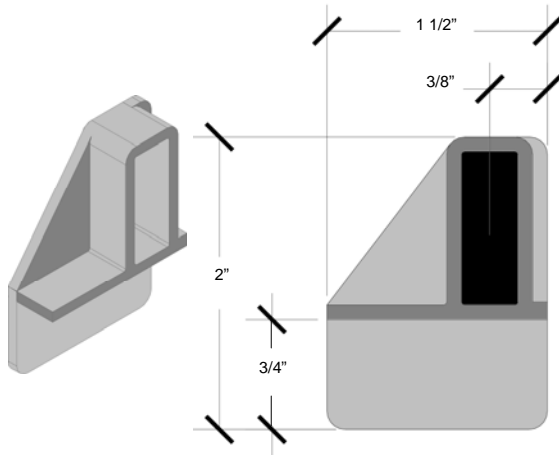

Bracket Description:

#950BK240 bracket has extra large back plate for easy stapling access.

Fastening:

2 pan head #6 screws or 3 -1/4" headed staples

ITEM#	SIZE	SOLD IN PAIRS
950BK240R	ADJUSTABLE REAR BRACKET—RIGHT HAND	
950BK240L	ADJUSTABLE REAR BRACKET—LEFT HAND	

Made in the USA

200 and 950 Series P-Bend Rear Mounting Brackets



260 Plug-In Bracket

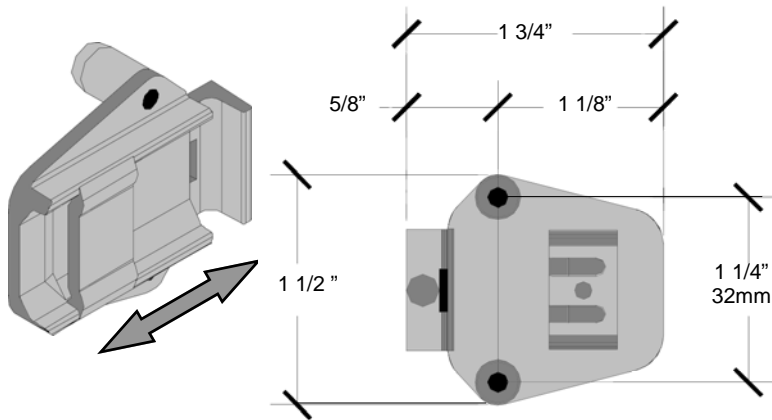

Bracket Description:
Bracket comes standard on 950HP slides or with any P-Bend rear. Bracket attached at factory.

Boring:
Bore two 8mm diameter holes in cabinet back spaced at 32mm c/c.

ITEM#	DOWEL LENGTH	SIZE	SOLD IN PAIRS
260.3125	1/4"	FOR 1/8" CABINET BACK—NON-HANDED	
260.4375	7/16"	FOR 1/8"+ CABINET BACK—NON-HANDED	
260.562	9/16"	FOR 1/8"+ CABINET BACK—NON-HANDED	
260.6875	11/16"	FOR 1/2" CABINET BACK—NON-HANDED	

261 Screw-in Type

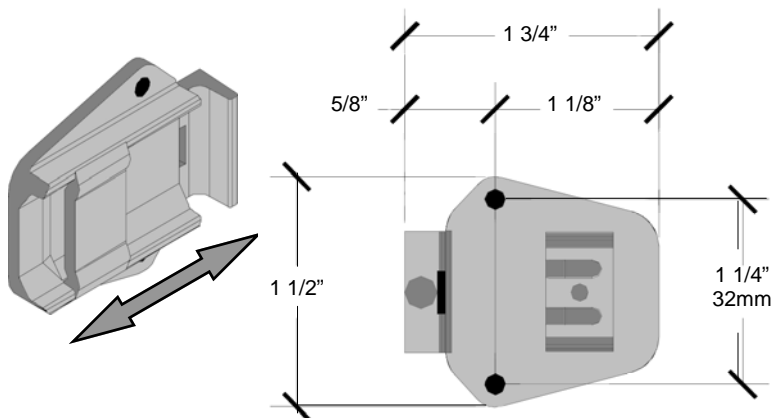

Bracket Description:
Bracket comes optional on 950HP slides or with any P-Bend rear.

Screw Fastening:
2 truss head #6 screws located in provided holes.

ITEM#	SIZE	SOLD IN PAIRS
950BK261	#6 SCREW HOLES	

Made in the USA

1209 Adjustable Pilaster Rollout Support System

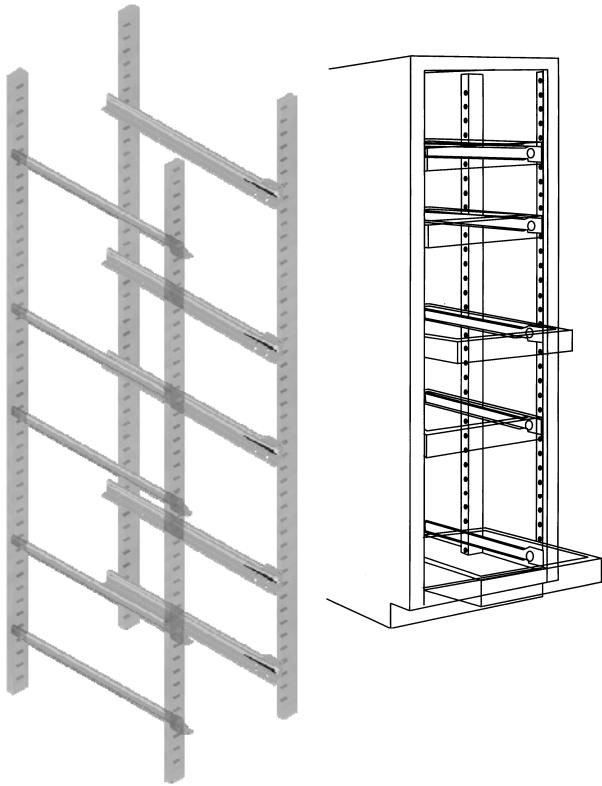

ONE PANTRY KIT SHOWN

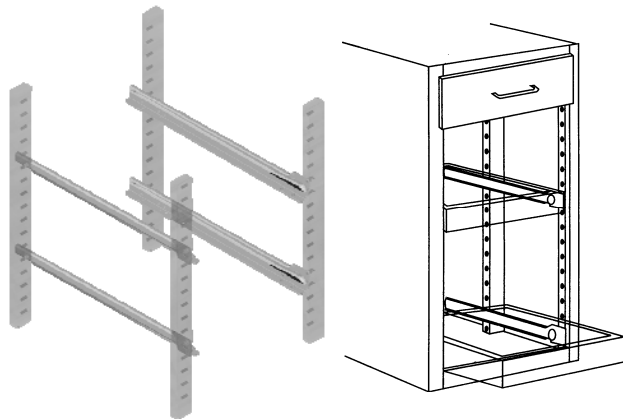

ONE BASE KIT SHOWN

SPECIFICATIONS:

Drawer Slides: Cold Rolled Steel
Colors: White
Capacity: 100 lbs loading
Drawer Fastening: Side or Bottom
Packaging: Single Kit, 10 Kit Pack

Base Pilaster:

- Part# **1209BP21.4375**
- Length is 21 7/16", holes are 8mm to accept attached cabinet track dowels. Holes are spaced 32mm c/c.
- Soft maple (Birch or other woods may be substituted)

Pantry Pilaster:

- Part# **1209PP58**
- Length is 58", holes are 8mm to accept attached cabinet track dowels. Holes are spaced 32mm c/c.
- Soft maple (Birch or other woods may be substituted)

FEATURES:

- Quattro captured for accurate tracking
- Roll formed for smooth, quiet roll
- Patented self-adjusting wheels for mounting tolerances
- Cabinet tracks with attached 8mm splined dowels.
- Pilasters with predrilled 8mm diameter holes on 32mm c/c for easy installation
- Pilasters and drawer slides available separately
- Additional drawer slides available upon request
- Custom length pilasters and custom colors available for an additional charge

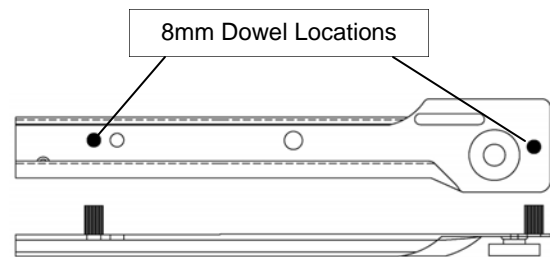

Base Kit#	Slides	Pilasters
1209B550	(2)-22" 550mm	(4)-1209BP21.4375
1209B500	(2)-20" 500mm	(4)-1209BP21.4375
1209B450	(2)-18" 450mm	(4)-1209BP21.4375
1209B400	(2)-16" 400mm	(4)-1209BP21.4375
1209B350	(2)-14" 350mm	(4)-1209BP21.4375

Pantry Kit#	Slides	Pilasters
1209P550	(5)-22" 550mm	(4)-1209PP58
1209P500	(5)-20" 500mm	(4)-1209PP58
1209P450	(5)-18" 450mm	(4)-1209PP58
1209P400	(5)-16" 400mm	(4)-1209PP58
1209P350	(5)-14" 350mm	(4)-1209PP58

Made in the USA

Full Extension Adjustable Pilaster Rollout Support System

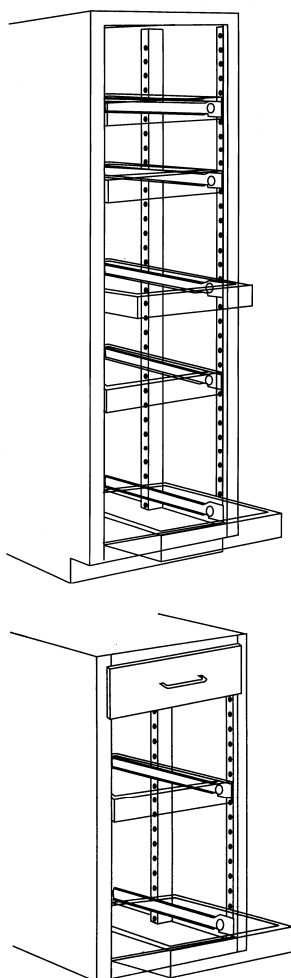

SPECIFICATIONS:

Drawer Slides: Full Extension Ball Bearing
Colors: Zinc Plated
Capacity: 100 lbs.
Drawer Fastening: Side
Packaging: Single Kit, Bulk

Base Pilaster:

- Part# **1209BP21.4375**
- Length is 21 7/16", holes are 8mm to accept attached cabinet track dowels. Holes are spaced 32mm c/c.
- Soft maple (Birch or other woods may be substituted)

Pantry Pilaster:

- Part# **1209PP58**
- Length is 58", holes are 8mm to accept attached cabinet track dowels. Holes are spaced 32mm c/c.
- Soft maple (Birch or other woods may be substituted)

FEATURES:

- Full Extension ball bearing drawer slides.
- Cabinet tracks with attached 8mm dowels.
- Pilasters with predrilled 8mm diameter holes on 32mm c/c for easy installation.



Base Kit#	Full Ex Slides	Pilasters
1209FXB550	(2)-22"	(4)-1209BP21.4375
1209FXB500	(2)-20"	(4)-1209BP21.4375
1209FXB450	(2)-18"	(4)-1209BP21.4375
1209FXB400	(2)-16"	(4)-1209BP21.4375

Pantry Kit#	Full Ex Slides	Pilasters
1209FXP550	(5)-22"	(4)-1209PP58
1209FXP500	(5)-20"	(4)-1209PP58
1209FXP450	(5)-18"	(4)-1209PP58
1209FXP400	(5)-16"	(4)-1209PP58

Full Extension Drawer Slides are Imported, Final Assembly in the USA

Pilaster Specifications



Houck Pilasters are made out of soft maple or other soft woods and are easily cut to fit most applications. The centerline of the holes are 32mm. Base cabinet and pantry cabinet lengths are available.

"A" Pilaster Base Part A228		"B" Pilaster Base Part B228		"A" Pilaster Pantry Part A588		"B" Pilaster Pantry Part B588	
Length	21 7/16"	Length	21 7/16"	Length	58"	Length	58"
Width	3/4"	Width	1 1/2"	Width	3/4"	Width	1 1/2"
Thickness	1 1/2"	Thickness	3/4"	Thickness	1 1/2"	Thickness	3/4"
Hole Size	8mm	Hole Size	8mm	Hole Size	8mm	Hole Size	8mm
Hole Quantity	17	Hole Quantity	17	Hole Quantity	46	Hole Quantity	46
"A" Pilaster Base Part SPA205		"B" Pilaster Base Part SPA205		"A" Pilaster Base Part SPA585		"B" Pilaster Base Part SPB585	
Length	20"	Length	20"	Length	58 7/8"	Length	55 7/8"
Width	3/4"	Width	3/4"	Width	3/4"	Width	3/4"
Thickness	1 1/2"	Thickness	7/8"	Thickness	1 1/2"	Thickness	7/8"
Hole Size	5mm	Hole Size	5mm	Hole Size	5mm	Hole Size	5mm
Hole Quantity	15	Hole Quantity	15	Hole Quantity	46	Hole Quantity	46

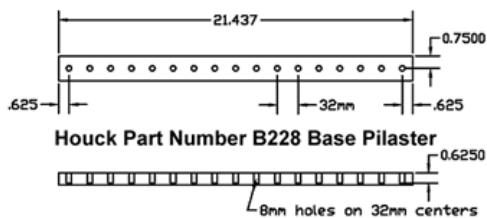
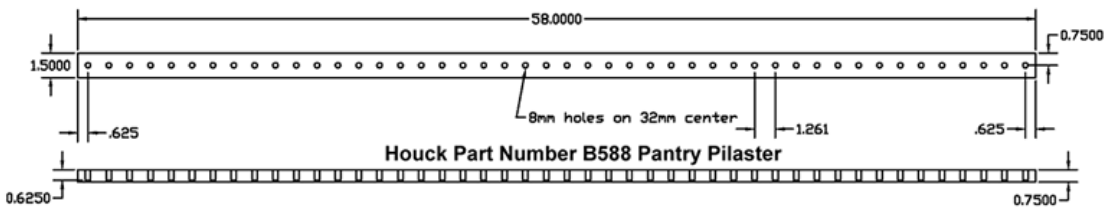
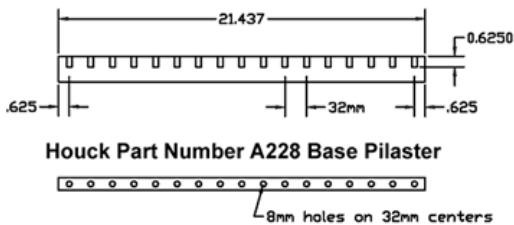
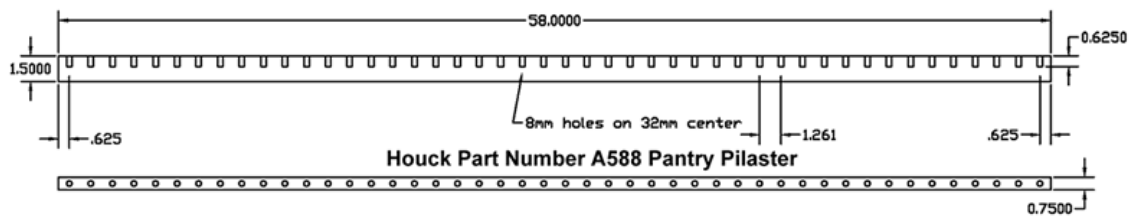

Made in the USA

Pilaster Specifications



Houck Pilasters are made out of soft maple or other soft woods and are easily cut to fit most applications. The centerline of the holes are 32mm. Base cabinet and pantry cabinet lengths are available.

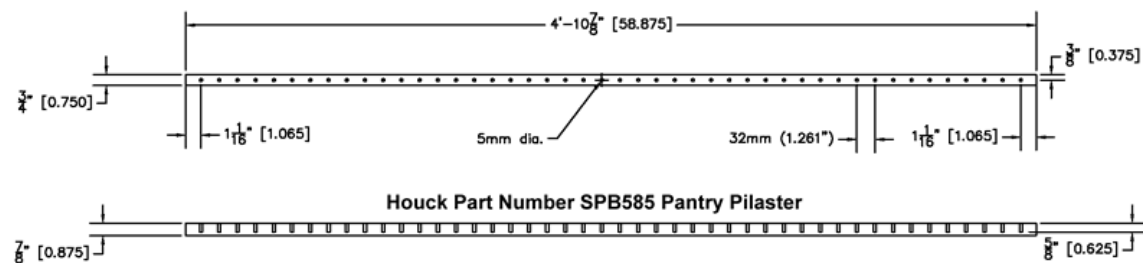
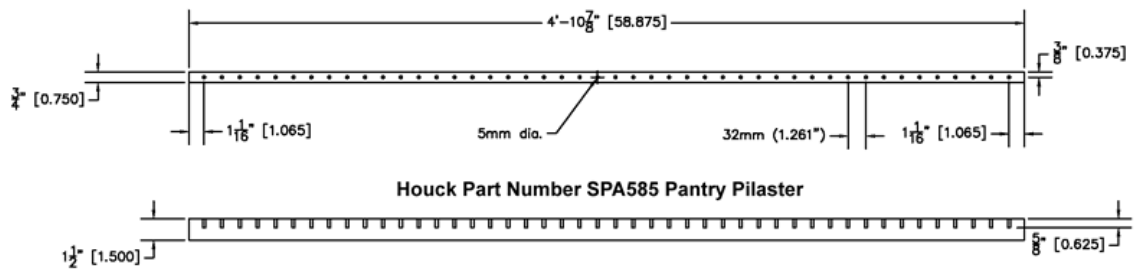
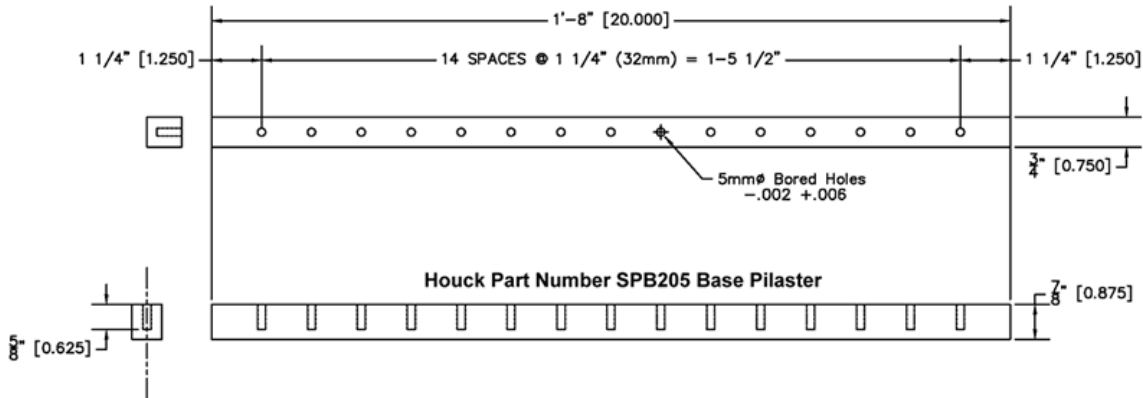
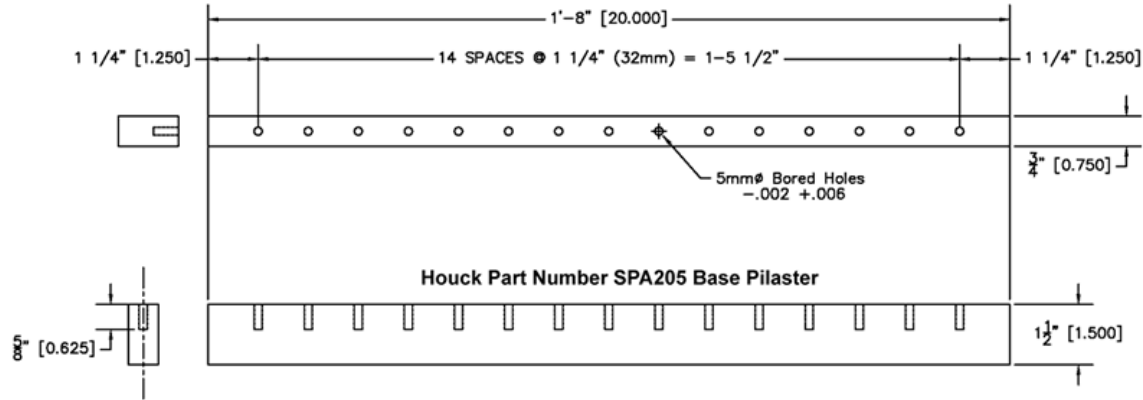

Made in the USA